

# DER EINFACHE UND SMARTE EINSTIEG IN DIE MODULARE SFT 5-A SPANNTÉCHNIK 120

NEU  
NEW

ENTERING THE MODULAR SFT 5-AXIS CLAMPING  
TECHNOLOGY THE SMART AND EASY WAY



**5 EINSCHRAUBBACKEN**  
SCREW-ON JAWS



**4 STANDARDBACKE**  
STANDARD JAW



**3 SPINDELVERLÄNGERUNG**  
SPINDLE EXTENSION



**2 SPANNEINHEIT BASISBLOCK + FESTER BASISBLOCK**  
CLAMPING UNIT BASE BLOCK + FIXED BASE BLOCK



**1 SPANNSCHIENE 5-A**  
CLAMP RAIL 5-A

Beispielaufbau *Example set-up*

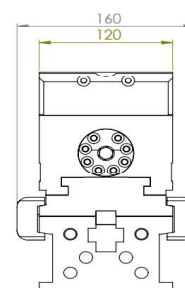
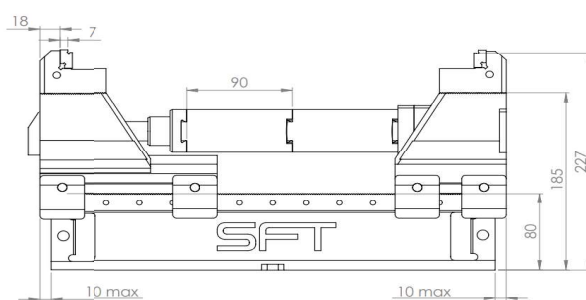
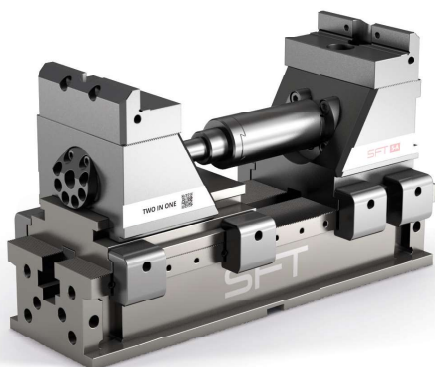
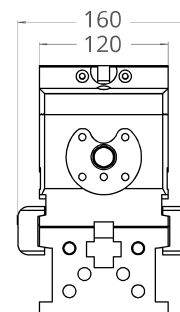
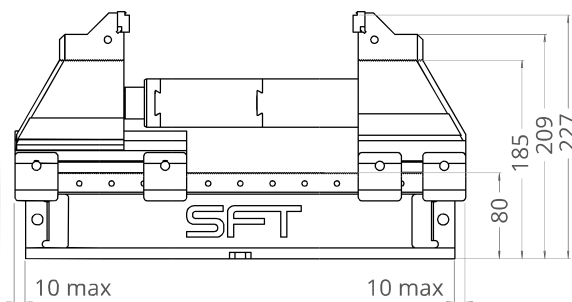

Beispielaufbau VS Spannung  
Example with extended range set-up

Artikel-Nr. Item No.	Länge Length	Spannweiten max Span width max	Anzahl Spindelverlängerungen Number of spindle extensions
<b>MULTISPANNER TWO IN ONE SET OHNE BACKEN</b> MULTIPLE CLAMPING DEVICE TWO IN ONE SET WITHOUT JAWS			
Y5A300.120.029	300	0-270	1x
Y5A400.120.029	400	0-370	2x
Y5A500.120.029	500	0-470	3x
Y5A600.120.029	600	0-570	4x
<b>MULTISPANNER TWO IN ONE SET INKL. 2 STANDARDBACKEN + 2 EINSCHRAUBBACKEN</b> (MIT STUFEN 3 MM UND 5 MM) MULTIPLE CLAMPING DEVICE TWO IN ONE SET INCL. 2 STANDARD JAWS + 2 SCREW-ON JAWS (WITH 3 MM AND 5 MM STEPS)			
Y5A300.120.129	300	0-270	1x
Y5A400.120.129	400	0-370	2x
Y5A500.120.129	500	0-470	3x
Y5A600.120.129	600	0-570	4x

Maximale Spannweite in Verbindung mit VS Aufbau. Maximum range in combination with extended range set-up.